

2 TO 8 GHz SINGLE-SIDEBAND ENHANCED UPCONVERTER

MODEL: SME0208LI1MD_* (IF Driven)

FEATURES

- RF output/carrier input 2 to 8 GHz
- IF bandwidth DC to 500 MHz (Q)
- Linear RF input Up to +5 dBm
- IF input power +10 to +16 dBm
- Sideband suppression 35 dB
- Carrier rejection 25 dB
- IF options:
 - Single sideband A, B and C
(internal hybrid)
 - Multioctave IFs Q (separate inputs)

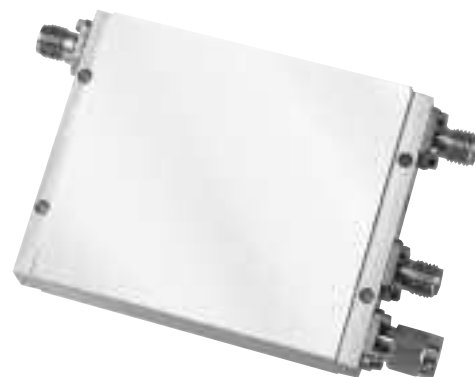

All modulators and SSB upconverters require that at least one of the input frequency bands (carrier or IF) has sufficient power to turn on the semiconductors. This model employs IF drive. SSB upconverters employ an internal IF 90° hybrid to yield only one RF sideband output. This is offset above or below the input LO by the IF frequency (test data is recorded for the upper sideband only). Schottky diode (standard) upconverters have the greatest speed and bandwidths, but yield RF output powers of typically less than 0 dBm. PIN diode (optional) designs can only be driven at modulation rates of less than 30 MHz, but will yield output RF powers exceeding +5 dBm. This IF driven unit is used when the RF input has a wide dynamic range, such as for military and commercial Doppler frequency or phase-shift generation. Enhanced sideband rejection (30 dB typ.) is obtained by using a multiple 90° cancellation circuit which is unique to MITEQ's design.

ELECTRICAL SPECIFICATIONS

INPUT PARAMETERS	UNITS	MIN.	TYP.	MAX.
RF carrier	GHz	2		8
RF VSWR (RF = 0 dBm, IF modulation = +13 dBm)	Ratio		1.5:1	
RF power (low-level diodes)	dBm	Noise	0	+5
IF modulation frequency range (Note 3)	MHz	DC		500
IF modulation power range (total I/Q)	dBm	+10	+13	+16
TRANSFER CHARACTERISTICS	UNITS	MIN.	TYP.	MAX.
Conversion loss (Note 1)	dB		8	12
Carrier suppression	dBc	20	25	
Sideband suppression (Note 2)				
Carrier – fundamental IF	dBc	25	35	
Carrier ±2 IF, 4 IF, etc.	dBc		40	
Carrier ±3 IF	dBc		13	
OUTPUT PARAMETERS	UNITS	MIN.	TYP.	MAX.
RF frequency range	GHz	2		8
RF VSWR (RF = 0 dBm, IF modulation = +13 dBm)	Ratio		2.5:1	

SME0208LI1MDA TYPICAL IF DRIVEN OUTPUT SPECTRUM TABLE

SSB UPCONVERTER (RF = 0 dBm, IF = +13 dBm total, IF = 30 MHz)

Frequency (GHz)	$f_0 + \text{IF}$ (I.L., dB) Note 1	$f_0 - \text{IF}$ (dBc)	f_0 (dBc)	$f_0 - 2 \text{ IF}$ (dBc)	$f_0 + 2 \text{ IF}$ (dBc)	$f_0 - 3 \text{ IF}$ (dBc)	$f_0 + 3 \text{ IF}$ (dBc)
2	-8.4	-31.8	-37.4	-40.6	-49.8	-12.8	-35.4
2.25	-8	-44.6	-34.6	-46.1	-51.2	-13.2	-37.4
2.5	-7.1	-44.6	-37.5	-55.2	-44.7	-14	-35.6
2.75	-7.4	-42.3	-39.7	-52.4	-42.8	-14.4	-35.1
3	-7.4	-43.3	-36.1	-47	-44.6	-13.9	-41.1
3.25	-7.1	-49.4	-32.5	-41.7	-48.6	-14	-41.4
3.5	-7	-40.1	-28.3	-41.3	-41.9	-14.2	-51.9
3.75	-8	-42	-28.3	-43.2	-40.9	-12.4	-33.9
4	-7.8	-30.3	-29.1	-46.3	-41.3	-13.2	-42.4
4.25	-7.8	-39.1	-30.3	-57	-38.8	-14.7	-33.8
4.5	-8.1	-29	-28.8	-51.6	-40.5	-15.2	-45.2
4.75	-8.4	-28.9	-28.9	-46	-41.4	-13.9	-37.4
5	-7.8	-41	-30.7	-43.9	-46.5	-14	-45.3
5.25	-8.3	-33.2	-42.3	-50.8	-44.4	-12.9	-41.6
5.5	-8.6	-36.4	-30.5	-53.9	-47.8	-13.1	-47.1
5.75	-8.3	-33.4	-30	-49.3	-45.4	-12.9	-35.7
6	-9.6	-33.5	-29.2	-41.9	-38.6	-14	-34.2
6.25	-9.1	-31.7	-36.5	-41.3	-46.5	-14.8	-38.2
6.5	-8.6	-34.3	-24.3	-37.9	-37.5	-13.9	-41.5
6.75	-8.8	-33.5	-20.5	-41.2	-39.4	-12.9	-40.4
7	-9.2	-31.3	-22.9	-37.5	-45	-13.3	-53.7
7.25	-9.3	-30.3	-26.3	-35.2	-31.6	-12.9	-49.3
7.5	-9.3	-32	-25.9	-48.7	-30.2	-13	-32
7.75	-10	-37.6	-25.8	-37.8	-36.4	-16.3	-33.5
8	-10.1	-27.7	-26.4	-35.1	-40.4	-15.8	-28.4

MAXIMUM RATINGS

Specification temperature..... +25°C
 Operating temperature -54 to +85°C
 Storage temperature -65 to +125°C

GENERAL NOTES

1. Insertion loss relative to 0 dBm RF input. All other outputs, including f_0 , are relative to the desired upper ($f_0 + f_m$) output.
2. Standard SSB units with IF hybrids are aligned for upper sideband operation. For lower sideband or selectable sideband, contact MITEQ.

3. Available part numbers: SME0208LI1MD

A = 20–40 MHz
 B = 40–80 MHz
 C = 100–200 MHz
 Q = DC–500 MHz

NOTE: Test data supplied at 25°C; per spectrum table.

OUTLINE DRAWING

BLOCK DIAGRAM

SME0208LI1MDA

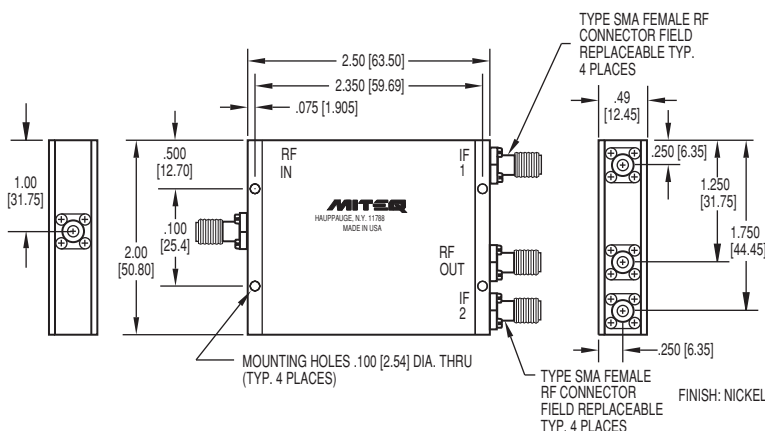

SME0208LI1MDA, B and C

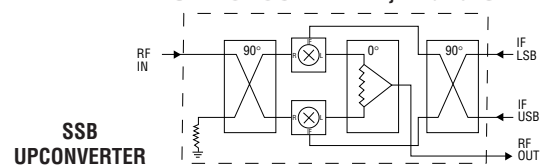

NOTE: All dimensions shown in brackets [] are in millimeters.