

43 TO 45 GHz LOW-NOISE FRONT END WITH LO MULTIPLIER OPTION

MODELS: SYSMM1X4345, SYSMM2X4345 AND SYSMM3X4345

FEATURES

- Low noise figure 3.6 dB typical
- High gain 29 dB typical
- Output 1 dB comp. +7 dBm typical
- Integrated packaging Hermetically sealed
- Integrated LO multiplier

The SYSMM3X4345 is an integrated low-noise converter with internal image filtering and LO multiplier. The integrated LO multiplier provides higher front end compression point than would be possible with a passive sub-harmonic mixer. Internal LO filtering reduces spurious and fundamental LO leakage. All devices are screened to MIL-STD-883 method 1010 and 1008 prior to hermetic sealing for high reliability. The single piece housing is a robust mechanical design for ease of use in any system. Waveguide inputs, alternate frequency bands, and quadrature or image rejection style units are available. Please contact MITEQ.

ELECTRICAL SPECIFICATIONS

INPUT PARAMETERS	CONDITION	UNITS	MIN.	TYP.	MAX.
RF frequency range		GHz	43		45
RF VSWR	50 ohm reference	Ratio		3:1	
V+ bias current	@ +9 to +16 V			380	
V- bias current	@ -9 to -16 V			30	
LO frequency range	SYSMM1X4345	GHz		41	
	SYSMM2X4345	GHz		20.5	
	SYSMM3X4345	GHz		13.67	
LO power range		dBm	+11	+12	+14
LO VSWR		Ratio		2.5:1	
TRANSFER CHARACTERISTICS	CONDITION	UNITS	MIN.	TYP.	MAX.
Conversion gain		dB	24	29	
Image rejection		dB	15	25	
Single-sideband noise figure		dB		3.6	4.5
Output power at 1 dB compression point		dBm		+7	
OUTPUT PARAMETERS	CONDITION	UNITS	MIN.	TYP.	MAX.
IF frequency range		GHz	2		4
IF VSWR		Ratio		2.5:1	

NOTE: Test data supplied at 25°C; conversion gain, image rejection, noise figure and output 1 dB compression point.

MAXIMUM RATINGS

Specification temperature +25°C
 Operating temperature -40 to +65°C
 Storage temperature -65 to +95°C



SYMM1X4345, SYMM2X4345 AND SYMM3X4345

OUTLINE DRAWING

STANDARD UNIT

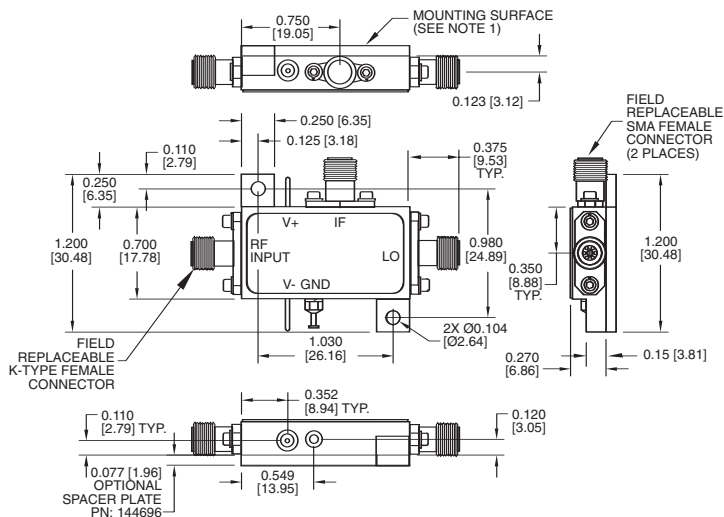

NOTES:

- Units mounting surface shall be attached to a heatsink capable of dissipating the devices power consumption without exceeding the devices temperature limits.
- All dimensions shown in brackets [] are in millimeters.

ORDERING INFORMATION

- SYMM3X4345Front end with 3X LO multiplier
- SYMM2X4345Front end with 2X LO multiplier
- SYMM1X4345Front end with fundamental LO
- SYMM3X4345WG1Front end with 3X LO multiplier and RF waveguide port
- SYMM2X4345WG1Front end with 2X LO multiplier and RF waveguide port
- SYMM1X4345WG1Front end with fundamental LO and RF waveguide port

Standard waveguide interface has 0.116 diameter clearance holes.
For waveguide port with #4-40 tapped holes, substitute...WG2 for...WG1.

AVAILABLE OPTIONS

PART NO.	DESCRIPTION
OPT143047	External DC-DC converter to generate -V for single supply requirements
OPT163370	Heat sink for non-waveguide unit
OPT144696	Spacer plate for non-waveguide unit (used when mounting unit to a flat surface, plate allows clearance for connectors)
OPT147307	L-shape mounting bracket

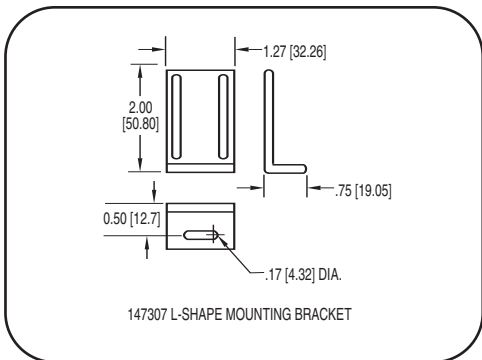

BLOCK DIAGRAM

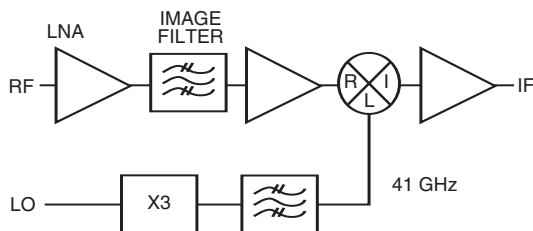

TYPICAL APPLICATION

