

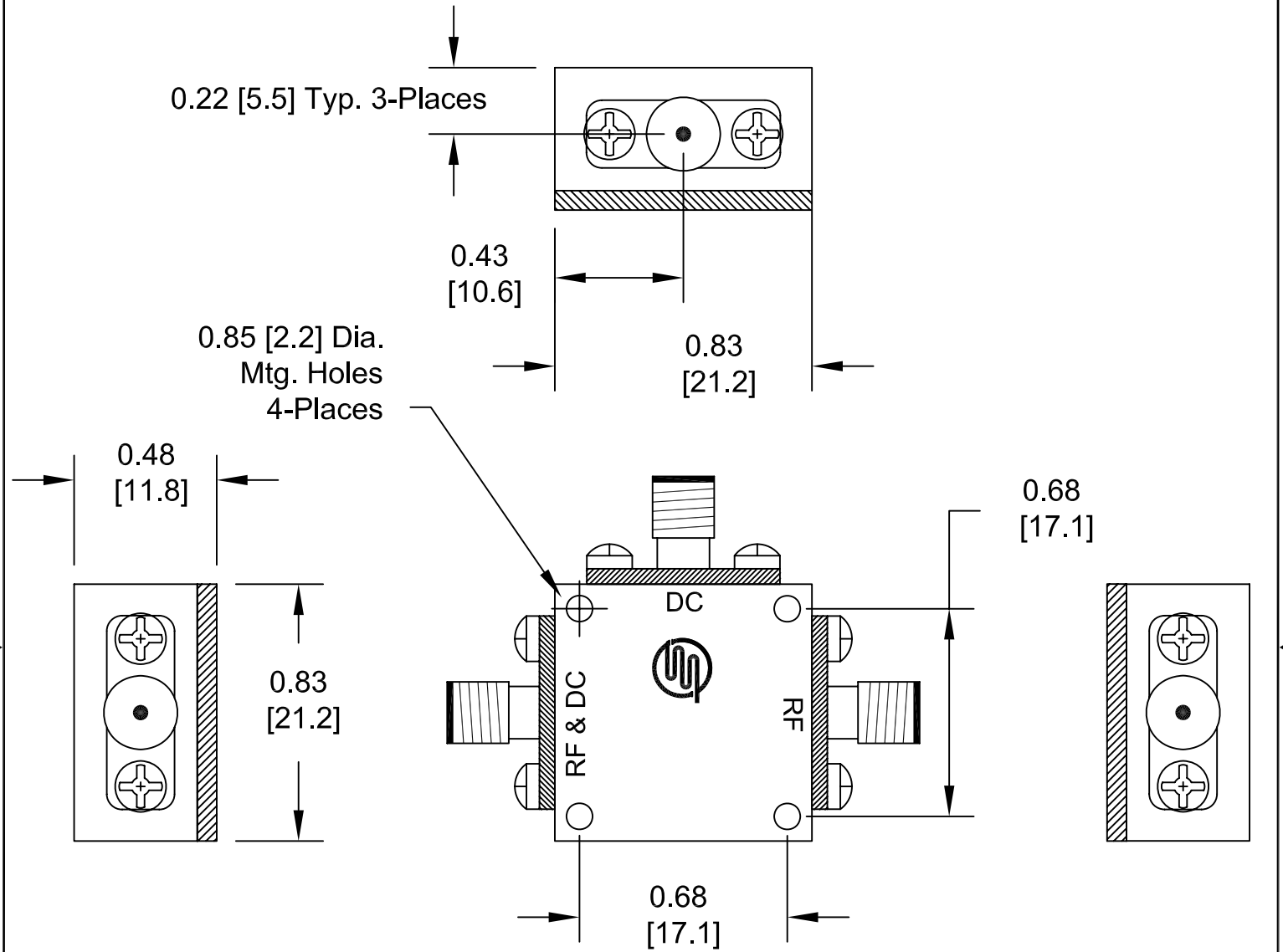

DASH NO.	APPLICATION		REVISIONS			
	NEXT ASSY	USED ON	LTR	DESCRIPTION	DATE	APPROVED
			A	INITIAL RELEASE DWO# 91011126	6/18/2007	<i>L. Kammer</i>



**(OUTLINE #16)**  
**(Bias Tee)**

ALL PAGES ARE OF ORIGINAL ISSUE (A) EXCEPT AS NOTED.	CONTR NO. 206600		 100 Davids Drive, Hauppauge, New York 11788			
	PREP BY <i>L. Kammer</i>	DATE 6/18/2007				
	CHKD BY <i>L. Kammer</i>	DATE 6/18/2007	OUTLINE DRAWING AMPLIFIER			
	PROJ ENGR <i>B. Pope</i>	DATE 6/19/2007				
	APPROVAL (PROJ)		SIZE A	CODE IDENT. NO. 33592	176604	
	APPROVAL (GOVT)		SCALE	REV. A	SHEET 1 OF 1	